



USER MANUAL

JEROME® 431-X MERCURY VAPOR ANALYZER OPERATION MANUAL

December 2015

ARIZONA INSTRUMENT LLC

3375 N Delaware Street | Chandler, AZ 85225 USA
800.528.7411 | 602.470.1414 | f 602.281.1745

www.azic.com

Email:

General – azi@azic.com

International – intl@azic.com

Customer Service – support@azic.com

JEROME[®] 431-X Mercury Vapor Analyzer Operation Manual



PROPRIETARY RIGHTS NOTICE

This manual contains valuable information and material developed by Arizona Instrument LLC for use with the Jerome[®] 431-X Mercury Vapor Analyzer. No part of this manual can be reproduced or transmitted in any form or by any means, electronic, mechanical or otherwise. This includes photocopying and recording or in connection with any information storage or retrieval system without the express written permission of Arizona Instrument LLC.

ALL RIGHTS RESERVED

© Copyright 1990-2015 Arizona Instrument LLC

Resisorb[®] is a registered trademark of Avantor Performance Materials.
Tygon[®] is a registered trademark of Norton.

Table of Contents

1. FOR THOSE WHO CAN'T READ THE WHOLE MANUAL NOW.....	5
2. INTRODUCTION	7
3. PRINCIPLE OF OPERATION.....	8
Zero Air Filter	9
4. INSTRUMENT OPERATION	10
LCD Codes	10
Daily Operations.....	11
Sensor Regeneration	12
Zero Adjust.....	13
Sample Mode.....	14
Survey Mode	15
Operating on AC Power or Generator	16
Operating on Internal Battery Power	16
External battery power	16
Charging Batteries.....	17
Obtaining Maximum Battery Life	17
5. MAINTENANCE.....	18
Preventive Maintenance Calendar	18
Flow System	19
.25 inch Fritware Filter	19
Internal Filters	20
Replacing the Battery Pack.....	21
Setting the Input Voltage and Frequency	21
Display Nanograms or Milligrams Per Cubic Meter	22
Changing the Fuse	22
6. CALIBRATION.....	23
Verification of Functionality and Quality Control	23
7. 431-X TROUBLESHOOTING	24
8. JEROME® 431-X TECHNICAL SPECIFICATIONS	27
Optional Communications Capability	27
Instrument I/O Interface	28
Potential Interferences	29
9. ACCESSORIES & MAINTENANCE PARTS	30
Spare Parts.....	32
10. FACTORY CALIBRATION SERVICE	36
11. APPENDIX A - 431-X FUNCTIONAL TEST KIT	37
Preparation.....	37
Mercury Transfer	38
Vessel Disassembly	38
Replacing Mercury	39
Functional Test Procedure.....	39
Syringe Technique.....	41
431-X Temperature Conversion Chart	42
Functional Test Troubleshooting	43
12. APPENDIX B - INTERNAL DIP SWITCH SETTINGS.....	44
13. APPENDIX C - JEROME® COMMUNICATIONS SOFTWARE.....	45
JCS Kit Contents	46
System Requirements	46
Data Logger Option.....	46
14. APPENDIX D - JEROME® 431-X OPTION BOARD	47
Auto-Zero	47
Instrument Zeroing	47
Timed Regeneration	48

Auto-Sample.....	49
4-20 mA Analog Output.....	49
SW101 Functions:.....	49
Connection and Setup:.....	50
Fresh Air Solenoid.....	52
DC Power Operation	53
DC Power Adaptor Kit, AZI P/N Y031 0902	53
15. WARRANTY	55

An up-to-date electronic copy of this manual can be found at:
<http://www.azic.com/downloads.aspx>

1. FOR THOSE WHO CAN'T READ THE WHOLE MANUAL NOW

This manual contains details that will optimize the results and the life of your instrument. Read and refer to the manual for complete details on operation, maintenance and troubleshooting, special voltage inputs and data output.

The Jerome[®] 431-X is easy to operate and ready for use upon receipt from the factory.

- Remove the instrument from the packing material.

Retain all packaging materials for any future shipment of the instrument.

If the instrument is returned to AZI for any reason, it must be placed in the original packaging materials that have been tested and proven to be effective protection during shipment.

- Call AZI Customer Service at 800-528-7411 or 602-470-1414 for Return Material Authorization (RMA) information prior to returning a unit.
- For all shipments, boxes and packing materials are available from AZI.
- Pack the Jerome[®] instrument only in a Jerome[®] shipping container.

AZI WILL NOT BE RESPONSIBLE FOR SHIPPING DAMAGE. IF YOU RETURN THE INSTRUMENT IMPROPERLY PACKAGED OR SHIPPED, YOU SHOULD INSURE IT FOR FULL VALUE.

- Check for any damage and confirm receipt of all parts on your packing list. Contact Arizona Instrument Customer Service at (800) 528-7411 or (602) 470-1414 if you have any questions.
- Press the ON button. The display should read 000 in less than one second.
 - A LO BAT message appears briefly in the upper left corner.
 - If the LO BAT message persists, recharge the battery. See page 17.

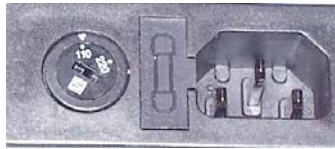

- Check the voltage setting (110 or 220 VAC) on the back of the instrument. Ensure that it is set to the correct voltage. If the pointer is not aligned to the local voltage, turn the selector to point to the correct voltage.
- 
- Perform a sensor regeneration by following these steps:
 - Connect the line cord between the connector on the back of the 431-X and an AC power outlet.
 - Press the ON switch and then press the REGEN button.
 - ◆ The instrument will begin a 10 minute regeneration cycle, indicated by .H.H.H flashing on the display. **Do not interrupt this cycle.** For a complete description of this process, see page 12.
 - ◆ If any error message, such as .P.P.P, appears on the display, see the “Troubleshooting” section beginning on page 24.
 - When regeneration is complete, zero the sensor by pressing the ZERO button and turning the zero adjust screw, located under the handle, until the display reads 0.
 - The instrument is now ready to sample.
 - To ensure the input to the instrument contains no Mercury Vapor or mercaptans, use a Zero Air Filter, AZI P/N Z2600 3905. The Zero Air Filter cleans the air sample and should produce sample readings of less than 0.003 mg/m³. Therefore, use the filter to:
 - Equilibrate the instrument to temperatures that are higher or lower than the instrument. Sample with filter installed until the reading is below 0.003 mg/m³.
 - Identify contamination within the unit.
 - Confirm the presence of Mercury Vapor when readings are elevated. Install filter and verify that the readings go down with filter installed.
 - When the instrument measures Mercury Vapor, the zero display will be replaced with a value.

CAUTION

Do not adjust the ZERO after the instrument has measured Mercury Vapor or before the next regeneration. (Occasionally the display may drop to .L.L.L (indicating low) between the initial zeroing and the first sample. It is OK to readjust the ZERO if the instrument has not measured Mercury Vapor.)

- The instrument is designed for ambient air monitoring. **DO NOT allow the probe or the instrument’s intake to be exposed to any liquid.**
- The instrument is not explosion proof.
- Press the SAMPLE button to start a 12 second sampling cycle.
- Perform sensor regeneration after each day’s testing.
- Perform another sensor regeneration and re-zero the instrument before each day’s use.
- Perform sensor regeneration after 30 days of storage or inactivity.

Call AZI Customer Service, at (800) 528-7411 from the United States and Canada or (602) 470-1414 if you have any questions. If you prefer, you may send e-mail to support@azic.com

2. INTRODUCTION

The Jerome[®] 431-X Mercury Vapor Analyzer is an ambient air analyzer with a range of 0.001 to .999 milligrams of mercury vapor per cubic meter (mg/m³ Hg).



CAUTION:

The Jerome[®] 431-X is for vapor use only.
DO NOT allow the probe or the instrument's intake
to be exposed to any liquid, dust
or other foreign material.



The 431-X is designed to be easy to operate for quick and accurate analysis of mercury vapor levels. It has few maintenance requirements. However, please take a moment to read this manual before attempting operation. If you have any questions about your application or operation, please call AZI Customer Service at (800) 528-7411 or (602) 470-1414 or e-mail support@azic.com for assistance.

431-X Features

- Automatic sensor regeneration when equipped with the communications option and used with the Jerome[®] Communication Software (JCS) program and the Jerome[®] data logger.
- Regulated film heat voltage during sensor regeneration. This allows the sensor to clean properly with voltages from 100-130 VAC (or 200-260 VAC).
- Survey mode can be locked in.
- DIP switch setting can change the digital meter readings from mg/m³ Hg to nanograms (ng) of Hg (see page 22).
- The Jerome[®] 431-X can be operated from 100-130 or 200-260 VAC. To change the default voltage range, refer to Setting the Input Voltage, page 21.

Accessories and Maintenance Parts

The Accessories and optional items available to support the 431-X are listed and pictured beginning on page 30.

Applications

- Ambient air analysis
- Regulatory compliance
- Quality control
- Scrubber efficiency testing
- Accuracy check for other Mercury Vapor monitors and control systems
- Mercury Vapor source detection
- Leak detection
- Portable Mercury Vapor detection

The Jerome[®] 431-X can be operated from 100-120 or 200-240 VAC. To change the default voltage range, See “Setting the Input Voltage” on page 21.

3. PRINCIPLE OF OPERATION

A thin gold film, in the presence of Mercury Vapor, undergoes an increase in electrical resistance proportional to the mass of Mercury Vapor in the sample.

When the SAMPLE button is pressed, an internal pump pulls ambient air through a scrubber filter and into the flow system.

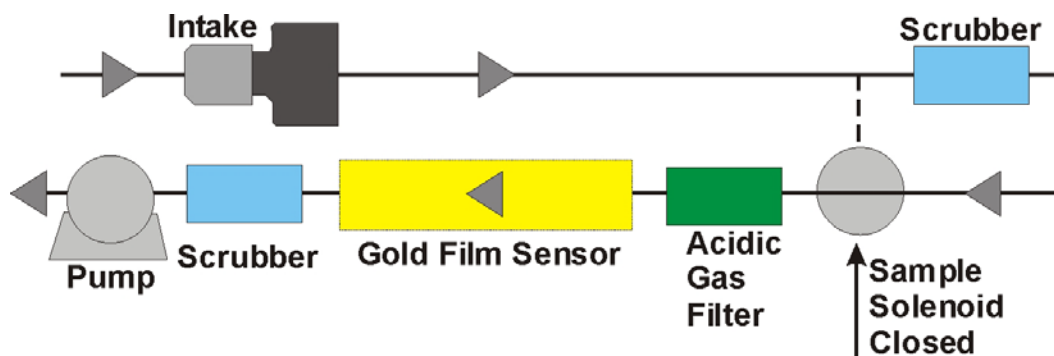

After 2 seconds, the sample solenoid bypass opens, closing off the scrubber filter from the flow system.

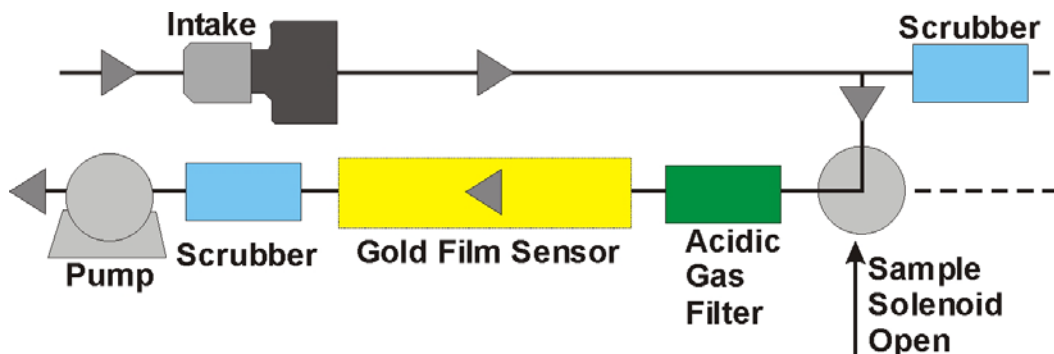

The sample air passes through a filter (removing any acidic gases which interfere with the sensor's response to mercury) and is drawn over the gold film sensor. The sensor absorbs the Mercury Vapor. Nine seconds after starting, the sample solenoid bypass closes and the remainder of the sample is drawn through the scrubber filter and the flow system. The instrument determines the amount absorbed and displays the measured concentration on the digital meter in milligrams per cubic meter (mg/m^3) of mercury. An internal DIP switch can be used to change the digital meter display from mg/m^3 to nanograms of mercury (see page 22).

The instrument's microprocessor automatically re-zeroes the digital meter at the start of each sample cycle and freezes the meter reading until the next sample cycle is activated, thus eliminating drift between samples.

During the sample mode cycle, bars on the LCD represent the percentage of sensor saturation. Depending on the concentrations, approximately sixty-five samples containing $0.1 \text{ mg}/\text{m}^3 \text{ Hg}$ may be taken before the sensor reaches saturation. After absorbing approximately 500 nanograms of mercury, the sensor becomes saturated and needs to be cleaned. This is accomplished by a manually activated 10-minute heat cycle, or sensor regeneration that burns the mercury from the sensor. This mercury is absorbed on internal filters to prevent any external contamination. The solenoid bypass closes during the sensor regeneration cycle, causing the air to pass through the scrubber filter, providing clean air for the regeneration process. The flow system's final scrubber prevents contamination to the atmosphere from the desorbed mercury.

The heat generated during the regeneration may cause some low level thermal drift. To ensure maximum sample accuracy, wait 30 minutes after regeneration before zeroing and using the instrument.

Zero Air Filter

The Zero Air Filter removes mercury vapor, mercaptans, and hydrogen sulfide from the air sample. Readings with the filter installed should be near zero.

Because air that is cooler than the instrument will cause low readings and warmer air will cause higher readings, the Zero Air Filter should be used to equilibrate the unit to ambient air. Continuous sampling with clean air will not cause saturation of the gold film sensor but will equalize temperatures faster to allow accurate analysis to begin sooner.

The Zero Air Filter can also be used to identify contamination within the instrument. If the readings do not reduce to near zero with the filter installed, contamination should be suspected. If the readings do drop to near zero with the filter installed but elevate with the filter removed, the presence of Mercury Vapor at the sampled location is confirmed.

For more information on the use of the Zero Air Filter, contact customer service at 1-800-528-7411, 1-602-470-1414, or visit our web site at <http://www.azic.com>.

4. INSTRUMENT OPERATION

LCD Codes

LCD CODE	EXPLANATION
000	Ready to sample
.000	No Mercury Vapor reading
00.0	No Mercury Vapor reading, display in nanograms
.8.8.8	Sensor saturated-regeneration needed (refer to page 12)
.H.H.H	Sensor regeneration in progress (.H.H.H flashes)
.L.L.L	Re-zero needed (refer to page 13)
.P.P.P	Power cord required or low line power, <100 VAC (or 200 VAC) (see pages 16 and 17, Changing the Fuse, if .P.P.P remains on after the cord is connected.)
.H.L.P	High line power, greater than 130 VAC in 110 operation or 260 VAC in 220 operation
.LO BAT	Recharge batteries (refer to page 17)
.E.E.E	Same as LO BAT, automatically shuts off
.HL	Very high concentration has been detected. Refer to your safety policy for additional direction to confirm the concentrations."
DURING SAMPLING	
.-	0-25% sensor saturation
.--	25-50% sensor saturation
.---	50-75% sensor saturation
-.---	75-100% sensor saturation
DURING SAMPLING, USING SURVEY MODE	
-	Survey sampling (minus sign flashes continuously)
WHEN ZERO IS DEPRESSED	Adjust to 0 <u>only</u> after sensor regeneration. It is normal for the display to read H after sampling has started.
0	Zero, ready to sample
H	High, turn Zero potentiometer counterclockwise
L	Low, turn Zero potentiometer clockwise

Daily Operations

Before each day's use of the Jerome® 431-X, perform the following steps to verify proper instrument operation:

- Press the power ON button.
 - The digital meter displays 000.
 - ◆ (Disregard the digital meter's initial momentary reading.)
 - ◆ Recharge or replace the battery pack if the LO BAT indicator REMAINS ON. Refer to “Charging Batteries” on page 17 and/or “Replacing the Battery Pack” on page 21.
 - ◆ To ensure the instrument's electronics have stabilized, allow a 1-minute warm up before beginning the next step.
- Use the Zero Air Filter to equilibrate the instrument to ambient air temperature.
 - Install the Zero Air Filter in the instrument's intake.
 - Sample continuously until the readings stabilize.
- Perform sensor regeneration. Refer to page 12 for the procedure.
- Thirty minutes after sensor regeneration is complete, zero the instrument.



NOTE: For maximum accuracy, such as when testing with the Functional Test Kit, wait 30 minutes after the sensor regeneration cycle to re-zero the unit. For immediate use, the unit can be re-zeroed immediately after sensor regeneration.

- Press the SAMPLE button.
 - During the sample cycle, the digital meter displays bars (-, --, or ---) to indicate the amount of sensor saturation.
- At the end of the sampling cycle, read the digital meter.
 - The number shown on the digital meter is the Mercury Vapor concentration in mg/m³.
 - This value remains on the display until the next sample is taken.
 - The digital meter automatically zeroes at the start of each sample.
- At the end of each day's use, perform sensor regeneration as described in the next section.

DO NOT ALLOW MERCURY VAPOR TO STAY ON THE GOLD FILM SENSOR OVERNIGHT.

Sensor Regeneration

Sensor regeneration is needed to clear the 431-X sensor of any accumulated Mercury Vapor and to prolong the life of the sensor. This simple procedure should be done:

- At the beginning of the day on which the instrument is to be used.
- During the day when the sensor becomes saturated.
- At the end of the day before storing the instrument.
- At a minimum of 30 day intervals while the instrument is in storage.



CAUTION:

Ensure the voltage selector on the back of the instrument, near the power cord inlet connector, points to the local AC power value. See “Setting the Input Voltage” on page 21.

To clean and protect the sensor, the supplied AC power must be 100 to 120 VAC or 220 to 240 VAC, depending on the available power source.

Once sensor regeneration is initiated, DO NOT interrupt the cycle.



- Attach the power cord to the 431-X and plug it into AC power. AC power is required to thermally regenerate the sensor.
- Press the power ON button.
- Press the REGEN button.
 - The digital meter flashes .H.H.H for the duration of the 10-minute cycle and displays .0.0.0 when the cycle is completed.

DO NOT INTERRUPT THIS CYCLE.

Wait until the cycle is completed before continuing with the next step.

- A minimum 30-minute wait after the sensor regeneration cycle is complete ensures maximum sample accuracy. However, the unit can be used immediately following the sensor regeneration if necessary. When the sensor regeneration is complete, press ZERO and adjust the ZERO ADJUST pot until 0 appears on the display. Install the zero air filter in the intake and take several samples or lock the instrument into survey mode (see page 15). After approximately one minute, stop sampling and check the ZERO. Adjust to 0. Repeat sampling through the zero air filter until reading remains on 0.

NOTE: The digital meter will read .P.P.P after REGEN is activated if the power cord is not plugged in or if the instrument's fuse needs to be replaced. Connect the power cord, or if necessary, replace the fuse. See “Changing the Fuse” on page 22.

Zero Adjust

- To ensure air entering the instrument is clean, install the zero air filter in the instrument's intake and sample until the readings stabilize.
- While pressing the ZERO button, turn the ZERO ADJUST potentiometer (shown at right) using the trimmer tool until the digital meter reads 0.
 - If the LCD reads H, turn the ZERO ADJUST counter-clockwise;
 - If the LCD reads L, turn the ZERO ADJUST clockwise.



NOTE: A minimum 30-minute wait after the sensor regeneration cycle is complete ensures maximum sample accuracy. The unit can be used immediately following the sensor regeneration if necessary. When the sensor regeneration is complete, press ZERO and adjust the ZERO ADJUST pot until 0 appears on the display. Install the zero air filter in the intake and take several samples or lock the instrument into survey mode (see page 15). After approximately one minute, stop sampling and check the ZERO. Adjust to 0 if necessary. Repeat sampling through the zero air filter until sensor remains on 0.

NOTE: When ZERO is pressed, depending upon internal configuration, a number between 00 and 100 may appear on the display instead of H, L, or O. See APPENDIX B - INTERNAL DIP SWITCH SETTINGS on page 44 for details. If the instrument is configured with an Option Board, see APPENDIX D - JEROME® 431-X OPTION BOARD beginning on page 47.

CAUTION:

Do not turn the ZERO ADJUST potentiometer between samples.

Turn the ZERO ADJUST only after a sensor regeneration cycle otherwise invalid readings will result.

- Press the power OFF button and disconnect the power cord.
- The Jerome® 431-X is ready for sampling.

CAUTION:

The Jerome® 431-X is intended for vapor use only. DO NOT allow the probe or the instrument's intake to be exposed to liquids, dust or other foreign material. Moisture or liquids drawn into the instrument can damage the sensor and flow system.

Sample Mode

This mode, used for standard operation, produces optimum accuracy ($\pm 5\%$ at $0.100 \text{ mg/m}^3 \text{ Hg}$) with the Jerome[®] 431-X.

- Press the power ON button.
 - The digital meter displays 000. If the unit is set to display in ng, the digital meter displays 00.0. (Disregard the digital meter's initial momentary readings.) Recharge or replace the battery pack if the LO BAT indicator REMAINS ON. Refer to pages 17 and/or 21 for the procedure.
- To ensure the instrument's electronics have stabilized, allow a 1 minute warm up before beginning the next step.
- Press the SAMPLE button.
 - During the sampling cycle, the bar (or bars) shown on the digital display indicate the current percentage of sensor saturation. (Refer to Meter Display Codes, page 10, for code descriptions.)
 - The bar (or bars) flash after 2 seconds and again after an additional 7 seconds. This flashing signals the opening and closing of the solenoid sample bypass. (See the Principles of Operation on page 8 for details.)
- At the end of the 12 second cycle, read the digital meter.
 - The number shown on the digital meter is the mercury concentration in mg/m^3 (or ng). This value remains displayed until the next sample is taken. The digital meter automatically zeroes at the start of each sample.
- When the sensor is completely saturated, the digital meter displays .8.8.8 instead of a value. No further operation is possible until a sensor regeneration is performed. (Refer to page 12 for the Sensor Regeneration procedure.)
- Press the power OFF button when not in use. Install the zero air filter in the instrument intake during storage.

Sampling Notes

The Jerome[®] 431-X is intended for vapor use only. **DO NOT** allow the probe or the instrument's intake to come in contact with liquids, dust or other foreign material. Moisture or liquids drawn into the instrument can damage the sensor and flow system.

The Jerome[®] 431-X operates a minimum of 6 hours on a fully charged battery.

Use the probe (AZI P/N1400-2002) to locate mercury vapor in hard to reach places. Plug the probe directly into the instrument's intake.

Survey Mode

The survey mode takes samples every 3 seconds automatically. Use this mode to locate mercury spills or to assess areas of potentially high mercury concentrations. Sampling in the survey mode is not as accurate. Due to the decreased sample volume, the accuracy of the instrument is reduced to $\pm 20\%$ @ $.100 \text{ mg/m}^3$.

- Press the power ON button.
 - The digital meter displays 000. If the unit is set to display in ng, the digital meter displays 00.0. (Disregard the digital meter's initial momentary readings.) Recharge or replace the battery pack if the LO BAT indicator REMAINS ON. Refer to pages 17 and/or 21 for the procedure.
 - To ensure the instrument's electronics have stabilized, allow a 1 minute warm up before beginning the next step.
- Press and **hold** the SAMPLE button.
 - The instrument takes a normal 12 second sample, displays the concentration at the end of the cycle and then goes into the survey mode sampling every 3 seconds. The display flashes the measured concentrations at the end of each 3 second sample cycle.
- When you are finished surveying, **release** the SAMPLE button.
 - The final survey value remains displayed until the next sample is taken.

NOTE: Approximately 65 samples at $.1 \text{ mg/m}^3$ may be taken before a sensor regeneration is required.

- To lock the instrument in a survey mode:
 - Hold the SAMPLE button down until the sensor status indicator bar(s) "__" begins flashing on the display.
 - Press the ZERO button, then release the SAMPLE button.
 - The pump should continue to run and the display should update every 3 seconds.
 - The instrument remains in the survey mode until one of the following occurs:
 - ◆ The sensor is saturated
 - ◆ A LO BAT (low battery) signal is encountered
 - ◆ An HL (high mercury level) is encountered
 - ◆ The instrument is turned OFF.

Press the power OFF button when not in use.

Operating on AC Power or Generator

- For stationary use, the 431-X may be operated on AC power.
 - Operating the instrument on AC power at all times eliminates the need for the battery pack and its necessary maintenance.
 - The battery may be unplugged or removed completely whenever the instrument is operating on AC power.
- When a generator is used to power the Jerome[®] 431-X, a high quality line conditioner or voltage regulator is required to ensure a pure sine wave and regulated voltage is applied to the instrument. The gold film sensor may be damaged by voltage that varies in amplitude or by surges, spikes, and/or noise on the power line. **This is especially true during the sensor regeneration.**

Operating on Internal Battery Power

For portable use, the 431-X may be operated on Battery power.

- When you operate the instrument on battery power, please be aware of the following:
 - A fully charged battery pack, AZI P/N Z4000-0907, provides power for a minimum of six (6) hours of operation.
 - For operating more than six (6) hours, an extra fully charged battery pack is needed.
 - Complete battery recharging takes 14 hours. Refer to Charging Batteries on page 17.
 - The 431-X uses a rechargeable Nickel Cadmium (NiCad) battery. Dispose of worn-out batteries properly when you are replacing the battery pack.

External battery power

A special version of the Jerome[®] 431-X and a DC Power Kit are available to operate the instrument from a secondary DC source. The source may be a car/truck battery or a storage cell used in conjunction with solar panels.

Call AZI Customer Service at 800-528-7411, 602-470-1414, or e-mail support@azic.com for additional information.

Charging Batteries

- Press the power OFF button.
- Connect the AC power cord between the 431-X power receptacle and an AC power source.
 - Complete battery recharging takes 14 hours.
 - The 431-X contains a trickle charger so it may be continually plugged into an AC power source without damaging the battery pack.
- The battery pack may be charged outside the instrument with an optional AZI IDC Battery Charger. (AZI P/N 4000-1011, for 115 VAC, P/N 4000-1012, for 230 VAC)

Obtaining Maximum Battery Life

There are certain inherent limitations to NiCad batteries. The primary limitation is a memory effect that occurs when the batteries are partially discharged and then recharged, repeatedly. This memory leads to a drastic reduction in the usable battery life. To prevent this memory effect, periodically allow the battery pack to discharge completely, and then recharge the battery pack.

- To obtain maximum battery life, follow these three (3) steps:
 - At least once a month wait until LO BAT appears on the digital meter before recharging the battery pack.
 - Charge the battery pack when the LO BAT indicator comes on. Excessive discharge can damage the battery pack.
 - Before storing the instrument verify the power is OFF.
- When the batteries fail to hold a charge, the battery pack should be replaced.
 - Battery life under normal usage is approximately 1 year, depending on the number of charge and discharge cycles.

5. MAINTENANCE

Preventive Maintenance Calendar

To keep the Jerome[®] 431-X operating at peak performance, follow the maintenance schedule below as a guide. Since maintenance is more a function of application and amount of use rather than time, your requirements may be different from the listed schedule. Call AZI Customer Service at 800-528-7411, 602-470-1414, or e-mail support@azic.com for additional guidance for your environment and operation.

PART/COMPONENT	MAINTENANCE CYCLE	REFER TO PAGE
Charge batteries	At least once per month, after 1 month's storage, or when LO BAT appears	Page 17
Change .25 inch fritware	Weekly or as needed	Page 19
Change internal filters and tubing ¹	After 6 months of use or as needed	Page 20
Replace zero air filter ²	Annually	
Factory calibration	Annually	Page 23
Functional check	Monthly or as needed	Appendix A, Page 37
Replace batteries	Annually or as needed. The battery pack contains NiCad batteries. Dispose of properly.	Page 21

NOTE: Install the zero air filter into the instrument's intake during storage.

¹ C/M filters contain Sofnolime™. For safety information see the supplier's Material Safety Data Sheet (MSDS) or call AZI Customer Service at 800-528-7411, 602-470-1414, or e-mail support@azic.com for a copy. Dispose of all filters properly.

² Zero air filters and scrubber filters contain Resisorb®. For safety information see the supplier's Material Safety Data Sheet (MSDS) or call AZI Customer Service at 800-528-7411, 602-470-1414, or e-mail support@azic.com for a copy. Dispose of all filters properly.

Flow System

The Jerome[®] 431-X's flow system is the crucial link between the sensor and the sample. For the instrument to perform correctly, the flow system must be properly maintained. The user maintainable components of this system are the intake filter (.25 inch fritware), a C/M Filter, two scrubber filters and connecting tubing.

Check the Preventive Maintenance Calendar on page 18, for a suggested schedule for changing fritware and scrubber filters. The Tygon[™] tubing in the system must be free of crimps for proper flow.

Part	Part Number
Scrubber Filter	Z2600 3930
C/M Filter	Z2600 3928
.25 inch Fritware Filter	2600 3039
Tygon [™] Tubing - 1/8" I.D. (1')	2500 3001

.25 inch Fritware Filter

Replace the .25 inch fritware filter once each week or as needed. In dusty environments, the fritware filter may need to be replaced as often as once a day. Replacement .25-inch fritware filters are available from AZI, Consumable Sales at 800-528-7411 or 602-470-1414.

- Unscrew and remove the intake.
- Push the old fritware filter disc out of the intake with your trimmer tool.
- Avoid touching the new fritware disc with fingers. Use tweezers to insert the new fritware.
- Use the blunt end of the trimmer tool to seat the fritware disc firmly against the inner ledge of the intake.
- Screw the intake back on the Jerome[®] 431-X.

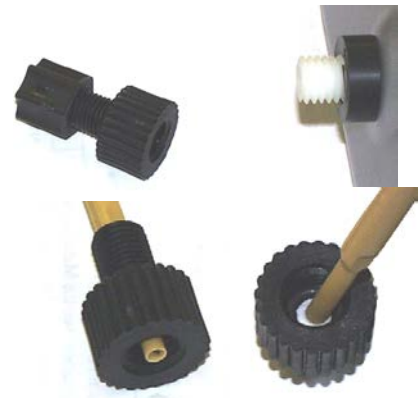

CAUTION:

The stem coming from the instrument onto which the outer intake housing is attached must be securely held in place. If loose, the tubing inside the instrument can become twisted when the intake housing is replaced. It may be necessary to open the instrument and tighten the hold-down nuts inside the instrument. Call AZI Customer Service at 800-528-7411, 602-470-1414, or e-mail support@azic.com if you have any questions



Internal Filters

- Replace the internal filters after six (6) months of use, or as needed.
- Press the power OFF button and unplug the power cord.
- Remove the two (2) side screws from the intake end of the instrument and open the case.
- Carefully disconnect the Tygon tubing from both ends of the filters and discard the old filters.



CAUTION:

Filters contain either Sofnolime™ or Resisorb®. Used filters will contain trace amounts of Mercury also. Use proper methods when disposing of used filters. Call AZI Customer Service at 800-528-7411, 602-470-1414, or e-mail support@azic.com for a copy of the Resisorb® or Sofnolime™ MSDS or for other questions.

- Connect the new filters to the Tygon tubing, ensuring all straight hose barbs point toward the intake/pump corner of the case and elbow hose barbs point toward the sensor housing as shown in the illustration.
 - Push the Tygon as far as it will go onto the filter fittings.
- Push the filters into the mounting clips.
- Remove any crimps or twists in the tubing and ensure that tubing connections are secure. If the tubing is loose, readings may not be accurate. Replace any tubing that has deteriorated due to heat and/or age.
- Close the case and replace the screws.
- Dispose of all filters in accordance with state and federal environmental regulations.

Replacing the Battery Pack

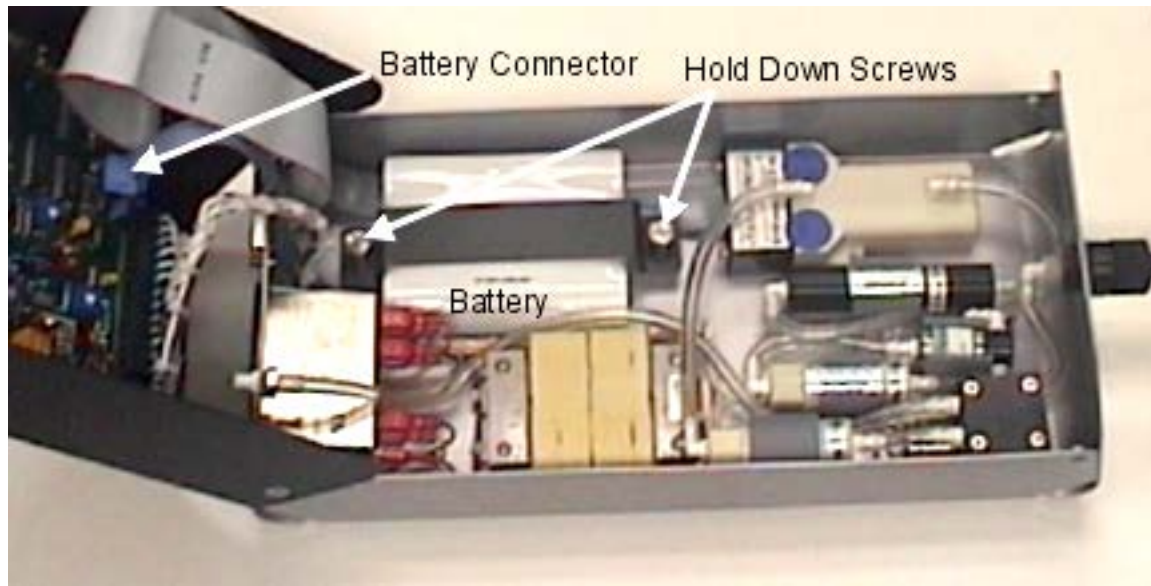

- Press the power OFF button.
- Unplug the power cord.
- Remove the two (2) side screws from the intake end of the instrument and open the case lid.
- Disconnect the battery connector from the board.
- Loosen the two (2) captive screws holding the battery bracket and remove the bracket.
- Remove the old battery pack and replace with a new battery pack.
- Replace the battery bracket and tighten the captive screws.
- Connect the new battery connector to the board.
- Close the case and replace the two (2) side screws.
- Dispose of the old NiCad battery in accordance with state and federal regulations.

Setting the Input Voltage and Frequency

Instruments are factory set and calibrated to use the power setting requested on the order. However, the voltage setting is easily changed to use either 110 or 220 VAC.

- Ensure the instrument is turned OFF and unplugged.
- Locate the voltage selector on the rear of the instrument.
- Insert a small screwdriver in the voltage selector slot and turn the selector until the arrow points toward your setting choice and a click is heard.

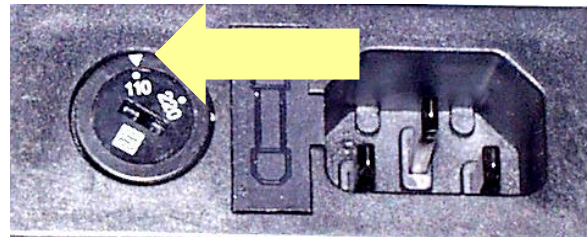

- Remove the two screws toward the front of the instrument and open the lid.
- Locate the DIP Switch SW2 at the top of the main circuit board. This is the red one illustrated at right
- Set SW2 position #1 and #6 as follows.

	60Hz	50Hz
Position #1	OFF	OFF
Position #6	OFF	ON



Display Nanograms or Milligrams Per Cubic Meter

The instrument is factory set to display mg/m^3 (milligrams per cubic meter) of mercury (.XXX). For some applications, the instrument's display can be converted to nanograms.

- Ensure the instrument is turned OFF.
- Remove the two screws near the front of the instrument and open the lid.
- Locate DIP Switch SW2 at the top of the main circuit board.
- Place Position #2 to OFF for nanograms display.
- Return Position #2 to ON for the normal milligram display.

Changing the Fuse

If the instrument display reads .P.P.P when the instrument is connected to AC power or when REGEN is pressed, or if the battery will not charge, the fuse may need to be replaced. The AC line power could also be less than 100 VAC (220 VAC). Check the fuse with an ohmmeter and the AC line power with a voltage meter.

- Locate the power receptacle on the rear of the instrument.
- Insert a small screwdriver in the slot, located in the power receptacle, and gently slide the fuse compartment out.
- If the fuse in the open-sided clip is open, remove and discard it.
- Replace the discarded fuse with the spare fuse located in the slide-out spare fuse compartment.
- Replace the fuse compartment in the power receptacle.
 - As soon as possible, replace the spare fuse with another 1A, 250V, time delay fuse, AZI P/N 5100 1012).

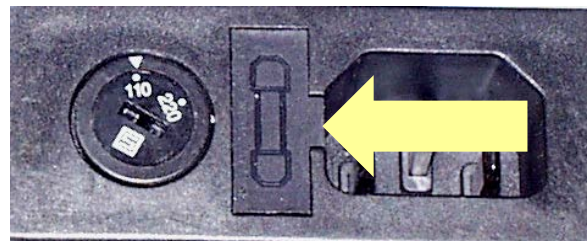

6. CALIBRATION

The Jerome[®] 431-X's gold film sensor is inherently stable and does not require frequent calibration. The interval between calibrations depends upon the application and frequency of use; however, the recommended interval is every 12 months.

The Jerome[®] 431-X has been factory calibrated using laboratory equipment containing NIST traceable permeation tubes. In order to calibrate the Jerome[®] 431-X, a sophisticated calibration system is required that ensures stability of the calibration gas source, eliminates any pressure in the calibration gas stream, and controls the temperature of the calibration environment.

We strongly recommend you take advantage of our calibration and maintenance service at Arizona Instrument. Call Customer Service at (800) 528-7411 or (602) 470-1414 to arrange re-calibration. A certificate of calibration is issued from AZI when your instrument is factory calibrated.

Verification of Functionality and Quality Control

The Functional Test Kit (FTK), AZI P/N Y431 0902, is used to determine if your instrument is functioning correctly between recommended annual factory calibrations. It allows you to have complete confidence in the sample results. This test verifies proper instrument operation through the introduction of a known concentration of Mercury Vapor into the Jerome[®] analyzer.

THIS IS A FIELD CHECK OF THE FUNCTIONALITY OF THE INSTRUMENT.

THIS TEST DOES NOT CALIBRATE THE INSTRUMENT.

If your application requires frequent verification of instrument function, this test demonstrates the unit's operation and function. Recording FTK results in an instrument log provides a quality control/quality assurance record of instrument function between regular calibrations. If test results fall within the expected range, you may assume the instrument is functioning correctly.

See APPENDIX A - 431-X FUNCTIONAL TEST KIT on page 37 for more information about the FTK procedures. Complete instructions for use are supplied with the test kit, AZI P/N Y431 0902.

To order the FTK, contact your AZI Sales Representative at (800) 528-7411 or (602) 470-1414.

7. 431-X TROUBLESHOOTING

Symptom	Possible Cause	Solution
Power Problems		
Unit does not turn ON. Unit turns on when power cord is plugged in. LCD displays 000 when instrument is operating on AC power.	Discharged battery or Dead battery.	Recharge battery for a minimum of 14 hours. Refer to page 17. Replace battery. Refer to page 21.
Unit does not turn on when connected to AC power cord.	Open fuse. Insufficient power. Internal component failure.	Replace fuse. Refer to page 22. Use a voltmeter to verify there is power to the AC outlet. Call AZI Customer Service for information at 800-528-7411 or 602-470-1414.
Regeneration & Zero Problems		
LCD displays .8.8.8.	Sensor saturated.	Do not attempt to adjust zero pot. The sensor must be regenerated. Refer to page 12 for information.
LCD displays .L.L.L when taking first sample.	Changes in temperature.	Readjust zero pot. See page 13 for information.
LCD displays H at finish of sensor regeneration when zero is pressed.	Internal contamination may redeposit Mercury Vapor from flow system onto gold film sensor.	Remove and replace fritware filter, intake filter disk, scrubber filters and Tygon tubing. Refer to "Flow System" on Page 19. Check tubing for kinks or crimps. Repeat regeneration cycle. Refer to page 12.
Zero adjust pot cannot be adjusted to 0.	Pot not turned sufficiently. Sensor may be ruptured or pot may be broken.	1. Turn zero adjust up to 20 times to reach the end. Pot will "click" softly. 2. If no "0", turn pot slowly in opposite direction until display reads "0". 3. If still unchanged, call AZI Customer Service at (800) 528-7411 or 602-470-1414.

Sampling Problems		
Airflow is restricted during the sensor regeneration cycle, causing possible permanent damage.	Kinks and crimps in the Tygon tubing.	Periodically check the Tygon tubing inside the instrument. Refer to page 20.
High erratic results.	Internal Mercury Vapor contamination.	<ol style="list-style-type: none"> 1. Install zero air filter in intake and tighten intake nut. Press SAMPLE button. After three samples, if readings are over 0.003 mg/m³, replace fritware filter and Tygon tubing. Refer to page 19. 2. Perform sensor regeneration with the zero air filter in intake. Refer to page 12. Retest if necessary. Replace scrubber filters and Tygon™ tubing. Refer to page 20.
High/erratic results	Intake and internal filters may become clogged and need replacement when sampling in a dusty or humid area.	<ol style="list-style-type: none"> 1. Open instrument and check for pinched, crimped or disconnected internal tubing. 2. In extreme conditions, an additional particle filter may be installed on the intake.
High/erratic results Readings vary more than 0.05 mg/m ³ when in survey mode.	Loose connections to gold film sensor.	Place a zero air filter into the intake. Place the instrument in survey mode. Move the unit as samples are being taken. Call AZI Customer Service at 800-528-7411 or 602-470-1414 for assistance.
Low response or erratic readings after a long period of non-use.	May need a second regeneration cycle.	<ol style="list-style-type: none"> 1. Wait 30 minutes and perform another sensor regeneration. 2. Test with FTK. Refer to page 37. 3. If still unresponsive, call AZI Customer Service at 800-528-7411 or 602-470-1414 for assistance.

False readings, may go to .8.8.8 or .L.L.L.	Extremely cold or extremely warm air sampled into unit.	If sampling under these conditions, install zero air filter in intake. Sample until display reads 0.003 mg/m ³ or less. This equilibrates sensor temperature with the temperature of the sample air stream. Remove filter and take samples.
Miscellaneous Problems		
Display reads .P.P.P when regeneration is attempted.	<p>Power cord not attached.</p> <p>Blown fuse.</p> <p>Line voltage less than 100 VAC (or less than 200 VAC for 220V units).</p> <p>Cycles dipswitch set incorrectly.</p>	<p>Check power cord for connection</p> <p>Replace fuse. Refer to page 22.</p> <p>Check line voltage settings. Refer to page 21.</p> <p>Check input cycle settings. Refer to 44.</p> <p>If fuse and line voltage are OK, it may be circuit board adjustment or component failure. Call AZI Customer Service at 800-528-7411 or 602 470-1414.</p>
Display reads .E.E.E	Very low battery.	Recharge battery. Refer to page 17. Replace battery. Refer to page 21.

8. JEROME® 431-X TECHNICAL SPECIFICATIONS

Range	0.001 to 0.999 mg/m ³
Detection Limit	0.003 mg/m ³ Hg
Precision	5% relative standard deviation at 0.100 mg/m ³ Hg
Accuracy	±5% at 0.100 mg/m ³ Hg
Response time-sample mode	12 seconds
Response time-survey mode	3 seconds
Flow rate	750 ± 50ml/min (0.75 ± .05 liters/min)
Power requirements	100-120 VAC, 50/60 Hz, 1 A, or 220-240 VAC, 50/60 Hz, 1 A
Fuse	F1A 250V, 5mm X 20mm
Internal battery pack	Rechargeable Nickel Cadmium:
- standard model	AZI P/N Z4000 0907
- XE model	AZI P/N Z4000 0908
Operating environment	0° to 40 °C, non-condensing, non-explosive
Case construction	Aluminum alloy
Dimensions – standard model	33 cm L x 15 cm W x 10 cm H (13" L x 6" W x 4" H)
Dimensions – XE model	35 cm L x 18 cm W x 18 cm H (14" L x 7" W x 7" H)
Weight – standard model	3.18 kilos (7 pounds)
Weight – XE model	3.5 kilos (8 pounds)
Digital meter display	Liquid crystal display (LCD)
Certification	CE mark on 220-240 V~, 431-XE model only.

Optional Communications Capability

- | | |
|-------------|--|
| Data output | <ol style="list-style-type: none"> 1. RS-232 Serial, Baud Rate 1200 for use with data logger, and/or Jerome® communication program. 2. RS-232 Serial data format with 0 & 20mA current logic levels; Baud Rate 1200 (special industrial applications) and Analog 20 mA output. |
|-------------|--|

"With Option Board" - See APPENDIX D - JEROME® 431-X OPTION BOARD on page 47.

Analog output	0 to 2V or 4 to 20 mA
Auto sample interval	5, 15, 30, or 60 minutes
Auto regeneration interval	6, 12 or 24 hours

Instrument I/O Interface

The 431-X I/O port (25 pin D-sub) provides the following functions:

- Serial data communication
 - Interface type: RS-232C full duplex, DCE
 - Parameters: 1200 Baud, 1 start bit, 8 data bits, 2 stop bits, no parity
 - Pin assignments:
 - Pin 1 Protective ground
 - Pin 2 Data in
 - Pin 3 Data out
 - Pin 7 Data ground
- Serial current loop
 - Interface type: 20mA current loop, full duplex
 - Parameters - 1200 Baud, 1 start bit, 8 data bits, 2 stop bits, no parity
 - Pin assignments:
 - Pin 1 Protective ground
 - Pin 4 Data out (+)
 - Pin 5 Data in (+)
 - Pin 14 Data out (-)
 - Pin 16 Data in (-)
- Switched battery connection for data logger
 - Pin assignments:
 - Pin 9 Battery (+)
 - Pin 7 Battery ground (-)
 - Pin 23 Battery ground (-)
- Unswitched battery connection for external battery pack pin assignments
 - Pin assignments:
 - Pin 15 Battery (+)
 - Pin 19 Battery (+)
 - Pin 7 Battery ground (-)
 - Pin 23 Battery ground (-)

NOTE: Pins 6, 8, 11, 17, 18, 20 and 21 are non-standard and should not be connected.

Potential Interferences

Potential interferences to the Jerome[®] mercury vapor analyzers are rare and most of these can be eliminated with proper maintenance procedures. However, erroneously high readings can sometimes occur. Here are a few things to be aware of when using the instrument:

The gold film sensors used in the Jerome[®] mercury vapor analyzers do not respond to the following compounds:

- Hydrocarbons
- CO, CO₂, and SO₂
- Water vapor (Note that water vapor condensation on the gold film can cause irreparable harm to the sensor and must be avoided.)

The C/M filter (AZI P/N: Z2600 3928), an acidic gas filter contained in the internal filter system, removes the following compounds that cause the gold film sensor to respond:

- Chlorine
- NO₂
- Hydrogen Sulfide (H₂S)
- Most mercaptans (organic sulfur compounds or “thiols”)

In areas containing these highly volatile compounds, the filter can quickly become saturated. In such situations, it is recommended that these gases be allowed to dissipate before sampling for the less volatile, more persistent mercury vapor. In addition, a special filter designed to remove chlorine gas from the sample stream is available from Arizona Instrument and may be ordered as Chlorine Filter, AZI P/N Z2600-3940.

Ammonia in very high concentrations can cause an off-gassing of accumulated acidic fumes from the internal acidic gas filter, resulting in positive readings on the instrument. In these cases, the ammonia odors are very strong. A special filter designed to remove ammonia gas from the sample stream is available from Arizona Instrument and may be ordered as Ammonia Filter, AZI P/N 990-0193. Again, either allow the vapors to dissipate or use the ammonia filter. Filter replacement at regular intervals, or when unexpectedly high readings are encountered in areas of these potential interferences, may resolve these problems.

Visit the “Tech Notes” section at www.azic.com for more information concerning the chlorine and ammonia filters.

Volatile mercury compounds in general will cause the gold film to respond. Alkyl organic mercuries such as methyl mercury (and other “straight chained” compounds) are typically extremely volatile and change the electrical resistance of the gold film sensor. Any such responses should be considered “qualitative,” **not** quantitative. The instruments are designed and calibrated to elemental mercury vapor only.

Inorganic mercury salts such as mercuric chloride are not very volatile. They may, however, generate some minute level of elemental mercury vapor to which the instruments will respond. This response, again, should be considered a qualitative response only.

9. ACCESSORIES & MAINTENANCE PARTS

PART #	ITEM DESCRIPTION
Y431 0901	431 Accessory Kit (See pictures beginning on page 32)
	1400 2002 Probe
	1400 3010 Tubing Adapter, 1/4" to 1/8"
	2300 0001 Trimmer Tool
	2600 3039 .25 Fritware
	6000 4003 Line Cord, 115 VAC - USA and Canada
	Alt. 200-0003 Line Cord, 220-240 VAC - England
	Alt. 200-0008 Line Cord, 220-240 VAC - Europe
	Z2600 3905 Zero Air Filter
Y431 0902	431 Functional Test Kit (See pictures beginning on page 32)
	A2600 0902 Stopper Assembly
	A2600 0903 Syringe Assembly
	A2600 0904 Mercury Vial
	2600 0022 Syringe Needles, 22 Ga. Reusable
	2600 0030 Calibration Vessel, Thermos
	3200 0011 Septa (20)
	Z2600 3905 Zero Air Filter
	Z2600 3914 Septum Holder
Y431 0903 or	431 Maintenance Kit (110 VAC) (See pictures beginning on page 32)
Y431 0904	431 Maintenance Kit (220 VAC) (See pictures beginning on page 32)
	2500 3001 1' of 1/8" Tygon tubing
	2600 3039 .25 inch fritware
	Z2600 3905 Zero Air Filter
	Z2600 3928 C/M Filter
	Z2600 3930 Scrubber Filter
	Z4000 0907 Battery Pack Assembly
Note: The Battery Pack Assembly for XE models is a different part number and must be ordered separately:	
	Z4000 0908 Battery Pack Assembly (XE models)

Y990-0259 **Jerome® Data Logger & JCS.**
Includes the Jerome® Data
Logger and Jerome®
Communication Software (JCS)
Kit (see below)



Y990-0257 **Jerome® Communication
Software Kit (JCS)**
(Data Logger not included)

Y990-0258
(software
upgrade only)











Y411 0904 **Hard Side Carry Case**
Includes a molded case with die
cut foam rubber inserts to hold
the Jerome® 431-X and
accessories.



1400 0052 **Soft Field Carrying Case**
Hand/shoulder case with pockets
for accessories.

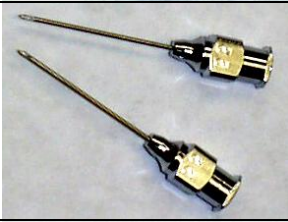

Spare Parts

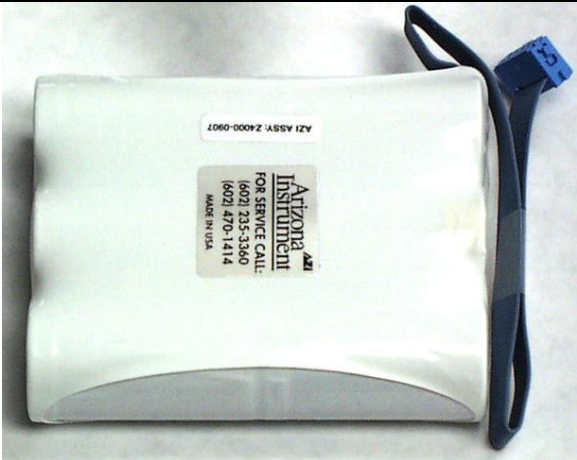
<p>A2600 0902 Stopper Assembly</p>	
<p>Z2600 3914 Septum Holder</p>	
<p>3200 0011 Septa</p>	
<p>A2600 0903 Syringe Assembly</p>	
<p>2600 0022 Syringe Needles, 22 Ga.</p>	
<p>1400 2002 Probe</p>	
<p>2300 0001 Trimmer</p>	
<p>1300 0031 1/8 x 3/16 reducer</p>	
<p>Z4000 0907 Battery Pack Assembly (115V)</p>	
<p>Z4000 0908 Battery Pack Assembly (230V)</p>	

Z2600 3905	Zero air filter		
Z2600 3928	C/M filter		
Z2600 3930	Scrubber filter		
Z2600 3940	Chlorine Filter		
990-0193	Ammonia Filter		
1400 3010	Tubing adapter		
Y2600 3945	Intake Kit		Includes mounting hardware
PS-151	Tube Nut		
2600 3039	.25 inch fritware		
2500 3001	Tygon tubing 1/8" I.D. (1 foot)		
2500 3002	Tygon tubing 1/16" I.D. (1 foot)		

4000 1011 115 VAC IDC
battery charger
(Used to charge
an uninstalled
battery)



4000 1012 230 VAC IDC
battery charger
(Used to charge
an uninstalled
battery)



6000 4003 100-120 VAC
Line Cord



Alternate –
200-0003 220-240 VAC
Line Cord for
England



Alternate –
200-0008 220-240 VAC
Line Cord for
Europe



990-0223 10 to 1 Dilution
Module



5100 1012 Spare Fuse



6000 1055 Jerome® Communication Cable



**For current prices and delivery information, call AZI Customer Service at
(800) 528-7411 or (602) 470-1414.**

10. Factory Calibration Service

Service includes filter replacement, component testing, and instrument calibration to NIST traceable standards.

**For scheduling and shipping authorization, call AZI Customer Service at
(800) 528-7411 or (602) 470-1414.**

11. APPENDIX A - 431-X FUNCTIONAL TEST KIT

If your application requires frequent verification of instrument functionality, this test will benefit you. If the test results fall within the expected range, you may assume the instrument is functioning properly.

THIS IS A FIELD CHECK OF THE FUNCTIONALITY OF THE INSTRUMENT.

THIS TEST DOES NOT CALIBRATE THE INSTRUMENT.

NOTE: Perform the functional test ONLY after a sensor regeneration.

The 431-X Functional Test Kit contains all accessories necessary to perform the functional test. See the complete list on page 30 and verify that all the parts to the kit are present.

CAUTION:

The vial and thermometer contain liquid mercury and are possible sources of mercury contamination. Follow the instructions for handling or transferring the mercury into the Functional Test Kit Vessel carefully.

For safety information, see the supplier's Material Safety Data Sheets (MSDS) or call AZI Customer Service at 1-800-528-7411 or 1-602-470-1414 for assistance in obtaining the MSDS.

Preparation

- Carefully unpack and inspect the parts of the kit.
- ENSURE that the mercury shipping container and mercury filled thermometer are not broken.
- In a ventilated area, preferably under a fume hood, remove the mercury vial from its shipping container.
- Place the functional test kit vessel and the mercury vial close to each other and open the mercury vial.

CAUTION:

The edge between the plastic case and the glass inner vessel of the functional test kit vessel are not sealed tight enough to prevent mercury from entering the area between the inner and outer vessels. ENSURE the mercury, transferred in the next step, does not contact the seal where the glass and plastic portions join.

NOTE: The vessel may be disassembled to transfer the mercury and better prevent contamination of the outer portion of the vessel. Instructions to disassemble the vessel can be found on page 38.

Mercury Transfer

- CAREFULLY pour the mercury into the center of the functional test kit vessel's opening.
 - ENSURE that no mercury residue is on the outside of the vessel. See the supplier's Material Safety Data Sheets (MSDS) or call AZI Customer Service at 1-800-528-7411 or 1-602-470-1414 for clean-up instructions.
- INSTALL the stopper assembly into the functional test kit vessel carefully, to prevent breakage of the thermometer.
 - PRESS the stopper assembly into the vessel to achieve a good seal.
- USE the 431-X instrument to verify that the outside of the vessel is not contaminated and the mercury vapor emission level, if any, is below the OSHA TLV for mercury.
- ALLOW the kit to adjust to room temperature for at least two (2) hours before using.
 - The temperature range for the test is 16 - 24 °C. Avoid temperature fluctuations.



CAUTION:

Do not use the calibration vessel as a portable container. If the calibration vessel is upset or greatly agitated, mercury droplets will cling to the thermometer stem, the rubber stopper, the mouth of the calibration vessel and the needle guide.



Vessel Disassembly



CAUTION:

The inner portion of the vessel is made of glass. Handle the vessel carefully to prevent breakage.



- LOOSEN, BUT DO NOT REMOVE the base of the vessel. The base unscrews from the body.
- SET the vessel on a firm surface.
- HOLD the base stationary and unscrew the body from the base.
- HOLD the base and the inner glass vessel with one hand while removing the body and gasket with the other hand.
- After the mercury is transferred into the glass inner vessel, reassemble in the reverse order.

Replacing Mercury

An oxide coating will form on the drop of mercury and will cause lower readings in your testing. Gently swirl the vessel to disturb the outer oxidized surface of the droplet. If this does not restore higher readings, it may be necessary to replace the mercury.

- Carefully remove the stopper assembly from the calibration vessel.



CAUTION:
BE SURE NEEDLE GUIDE IS FREE OF LIQUID MERCURY.



- Carefully pour the mercury into a disposal vessel. Refer to Vessel Disassembly Instructions on page 38.
 - Mercury can become trapped between the plastic calibration vessel and the glass inner-liner.
- Replace the oxidized mercury with approximately ½ cc fresh mercury. (AZI P/N A2600-0904)
 - Do NOT use the syringe for measuring liquid mercury. Dispose of oxidized mercury properly.
- Reassemble the calibration vessel.
- Reinstall the stopper assembly.

Functional Test Procedure

NOTE: Perform the functional test ONLY after sensor regeneration.

- Allow the calibration vessel to remain stable at room temperature for at least 2 hours.
 - The temperature range for the test is 16 - 24 °C.
 - Temperature fluctuations during the test procedure will produce erratic results.
- Replace the .25mm fritware.
 - Refer to page 19 for instructions.
- Replace the septum on the septum holder assembly.
- Plug the tubing adapter end of the septum assembly into the instrument's intake and tighten the intake tube nut.

NOTE: To check for a tight seal, gently pull on the septum holder assembly. If it comes out of the intake, it may be necessary to remove the intake tube from the instrument and firmly press the tubing adapter through the intake. Tighten the intake tube firmly to the intake stem.

- Attach a zero air filter to the septum assembly.
- Press power ON.
- Take 3 samples.

- If the average meter reading is greater than .005, stop here. The instrument may be contaminated. See 431-X TROUBLESHOOTING on page 24.
- If the average meter reading is less than .005, continue to the next step.
- Note the temperature of the calibration vessel.
- Press the SAMPLE button, wait 2 seconds and **when the display flashes**, inject 1 cc of mercury vapor according to the syringe technique described on page 41. Be sure all mercury vapor has been injected before the solenoid closes (second click and display flash).



CAUTION:
Carefully follow these instructions to minimize error.



- Record the meter reading.
- Repeat the instructions for mercury injection three more times.
 - The readings obtained for the last three 1cc injections should be within $\pm 5\%$ of each other.
- Refer to the Temperature Conversion Chart, page 42, for the acceptable range.
 - The average of the last three readings should fall within the range shown on the chart.

If the average is within range, the JEROME[®] 431-X is functioning properly.

- If the last three readings are not within $\pm 5\%$ of each other,
 - Perform sensor regeneration. Press ZERO and turn the ZERO ADJUST (refer to page 12 and 13 for the complete sensor regeneration procedure).
 - Wait 1 hour before proceeding to the next step.
 - Repeat the mercury injection test procedure.
 - If the average of the last three readings is still not within range, refer to the section on Functional Test Troubleshooting below.

Syringe Technique

- Pull and hold the syringe plunger against the bar-stop.
- Verify that the black mark on the syringe plunger aligns with the 1cc mark on the syringe barrel.
 - If it does not, the holder assembly must be adjusted. Call AZI customer service at 602-281-1745 or 800-528-7411 for assistance.
- Insert the needle into the needle-guide of the bottle stopper.

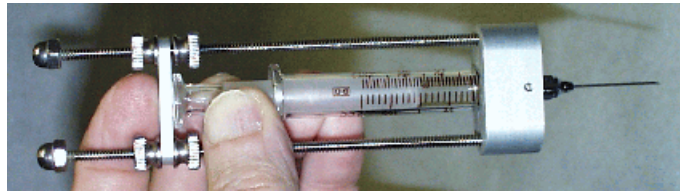

- Operate the plunger two or three times to pump mercury vapor into the syringe. On the final stroke, pull and hold the plunger against the bar-stop.
- Holding the plunger against the bar-stop, remove the syringe from the bottle and move it to the septum attached to the instrument intake.

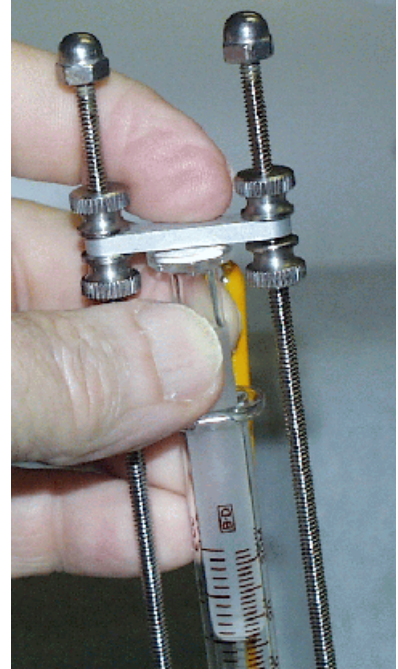

- Continue to hold the plunger against the bar-stop and insert the syringe needle into the septum.
- Press “SAMPLE” on the instrument.

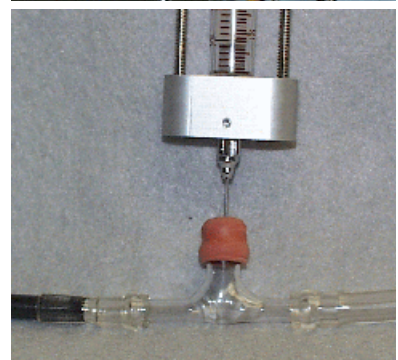

- When the display flashes, release the plunger and allow gravity to feed the mercury vapor into the airstream. If the plunger stops, gently press it completely closed.
- Remove the syringe needle from the septum.

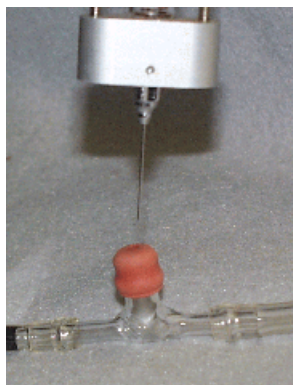

431-X Temperature Conversion Chart

Temperature in °C	Digital Meter Response
16	.091 to .123
17	.100 to .135
18	.108 to .146
19	.118 to .159
20	.129 to .174
21	.138 to .187
22	.151 to .204
23	.164 to .222
24	.177 to .240

Functional Test Troubleshooting

If you don't achieve good results with the functional test procedure, check the following:

Results	Solution
Typically too high	Ensure the calibration vessel temperature is stable.
Too Low	Be sure to inject the Hg vapor ONLY after the display flashes (approximately 2 seconds after SAMPLE is pressed).
	Ensure there is no oxidation on the mercury drop in the calibration vessel. Gently swirl the mercury drop in the calibration vessel. Replace if necessary.
	Ensure the instrument's intake is not blocked with foreign matter. Check flow with a flow meter.
	Ensure syringe is calibrated to 1cc. Use a new syringe needle. Straighten or replace crimped or blocked internal tubing.

If you find the above does not solve your problem, please call AZI Customer Service at 800-528-7411 or 602-470-1414.

12. APPENDIX B - INTERNAL DIP SWITCH SETTINGS

Main circuit board RED DIP switches (SW2)

This is the red DIP switch box located at the top, center of the instrument's main circuit board.



The 431-X provides regulated film heat at both 50 Hz and 60 Hz line frequencies. This also provides two ranges of preset but unregulated film heat (100-120/200-240 volt and 110-130/220-260 volt ranges). The two ranges are available to reduce the effects of chronic low or high line voltage.

Note: The ranges are doubled when the AC line selector switch is set to the 220V position. The DIP switch positions 1 and 6 must be properly set.

DIP 1	DIP 6	Function
OFF	OFF	60 Hz regulated film heat (100-130/200-260 VAC)
OFF	ON	50 Hz regulated film heat (102-130/205-260 VAC)
ON	OFF	50/60 Hz preset film heat (110-130/220-260 VAC)
ON	ON	50/60 Hz preset film heat (100-120/200-240 VAC)

Regulated film heat should normally be used (DIP 1 OFF) except in the few cases where extremely dirty line voltage conditions may exist. These conditions might be found where large motors are being controlled or other situations may exist where the voltage may vary outside the 100-130 VAC range with regularity. In those cases the two preset heat ranges will allow some degree of satisfactory operation.

Switch Number	Normal Position	Action
2	ON	Normal mode
	OFF	Nanograms mode
3	ON	Displays relative (not true) voltage during regen (0-255)
4	OFF	Display L-O-H when "zero" button pressed
	ON	Display 00-99 when "zero" button pressed
5	ON	Normal mode
	OFF	Locks into 0-10mg/m ³ range (survey mode)

13. APPENDIX C - JEROME® COMMUNICATIONS SOFTWARE

The Jerome® Communications Software (JCS) is used with 431-X Mercury Vapor Analyzers that feature the communications configuration option.

- The JCS allows the user to program the instrument for unattended monitoring and to download recorded data stored in the Jerome® data logger.
- Automatic sampling can be initiated every one (1) to sixty (60) minutes with programmable audible alarm levels.

The Jerome® Communications Software (JCS) operates with the Jerome® 431-X Mercury Vapor and Jerome® 631-X Hydrogen Sulfide Analyzers that have the “Communications Configuration” option installed. The software can control instrument sampling for unattended continuous operation, collect data, graph this data in real time and perform statistical analysis.

The software can also program the Jerome® Data Logger, AZI P/N 6100-0010. This optional accessory enables data storage during manual sampling or portable automatic sampling without being attached to a computer. The data logger initiates automatic sampling, triggers alarms and stores data. The logged data may then be downloaded to the computer when it is convenient. The data logger stores up to 1,000 data points.

The JCS is menu-driven and easy to use. Each display screen is designed for clarity with self-explanatory menu options, such as “Operate Instrument” or “Display Stored Data.” Select menu options using either a mouse or a track ball pointing device or a standard keyboard. The user creates records, or files, for computer storage of collected data. Data is easily retrieved for later viewing, graphing, printing or editing with spreadsheet or word processing software (not provided). Data can be used for ongoing record keeping or for fulfilling local regulatory requirements.

Before using this software, familiarization with the operation of the Jerome® Hydrogen Sulfide Analyzer or Mercury Vapor Analyzer is important. Also, prior to installation of this software you should be familiar with the personal computer and operating system you are using. If you have any questions about how to proceed, call AZI Customer Service at (800) 528-7411 or (602) 470-1414 or send an e-mail to support@azic.com for assistance.



JCS Kit Contents

- Jerome[®] Communication Software on CD-ROM with security key
- Jerome[®] Communication Cable, AZI P/N 6000 1055
- User's manual

System Requirements

- Jerome[®] 431-X with the “Communications Option.” These Jerome[®] instruments have a DB-25 connector and related internal hardware and firmware.
- Windows[®] 7 or 8
- At least one free serial port (or two free USB ports is using an RS-232/USB converter)
- One free USB port

Optional equipment:

- Jerome[®] Data Logger, AZI P/N 6100-0010 (to capture data without a computer nearby)

Data Logger Option

The software can also program the Jerome[®] Data Logger (AZI P/N 6100 0010) used with the Jerome[®] analyzer. The computer programs the data logger that then attaches to the DB-25 connector on the rear of the instrument. The data logger initiates automatic sampling, triggers alarms and stores data. This optional accessory enables portable automatic sampling without a dedicated computer.

14. APPENDIX D - JEROME® 431-X OPTION BOARD

Proper use of this board requires that the base instrument be fully functional and set correctly for the intended operation.

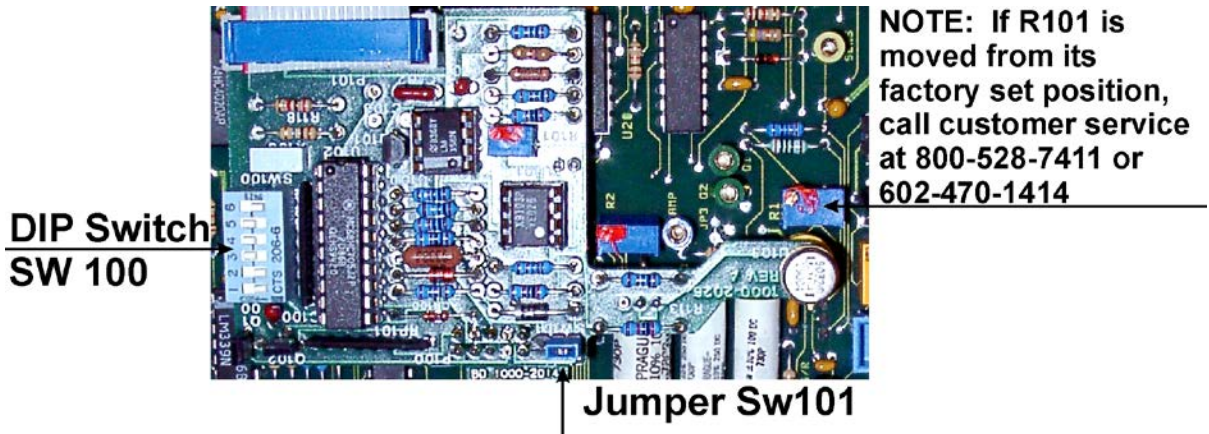

Auto-Zero

With the option board installed, the 431-X has a limited auto-zero function. This function cannot be disabled and is transparent to the user. The instrument can be manually zeroed as described in “Zero Adjust” on page 13. However, if the instrument is to be operated by personnel not familiar with the procedure or if it is operated unattended, the auto-zero function should satisfactorily zero the unit after each sensor regeneration.

Instrument Zeroing

The Jerome® 431-X has essentially three ways to zero the sensor reading before samples are taken if the option board is installed.

- The instrument automatically re-zeroes between samples so that each sample is a unique reading. To take a sample, simply press the SAMPLE button.
- The manually adjusted zero, using the switch on the top of the 431-X, is used to re-establish a baseline between the reference and sensor gold films **only after a sensor regeneration**. This zero is manually adjusted by pressing the ZERO button and turning the potentiometer on the top of the instrument until the display reads 0. **Adjust only after sensor regeneration**; it is normal for H to be displayed after sampling.
- The 431-X option board provides an auto-zero feature following regeneration that is invisible to the user.

- In some cases, the instrument cannot resume sampling after regeneration. .L.L.L appears on the display when the ZERO button is pressed and the error message “manual bridge adjust needed” is added to the notes column of the JCS text file when the JCS is used. If this problem persists, it may be necessary to re-set the auto-zero.
- When necessary to re-adjust the auto-zero point:
 - Turn the instrument off.
 - Make a note of the original DIP switch settings of SW100 on the option board.
 - On red DIP switch on the control board, SW2, turn DIP switch 4 to ON.
 - Set the switches on the option board’s blue DIP box, SW100, to 1,2,6 OFF; 3,4,5 ON.
 - Turn the instrument ON.
 - Press and hold the ZERO button and adjust the potentiometer on top of the instrument until the number 20 is displayed, then release the ZERO button.
 - Switch option board DIP #1 from OFF to ON three times leaving it set to ON. (i.e. starting from OFF, switch it ON, OFF, ON, OFF, ON).
 - Press and hold the ZERO button while turning the potentiometer on the option board until the number 20 is displayed. Note the display may flicker one digit.
 - Return all switches to their original position.

NOTE: The higher the auto-zero number, the lower the sensor capacity and the more sensor regenerations are needed.

Timed Regeneration

If the unit is to be operated unattended for extended periods, AZI recommends that the sensor be regenerated regularly. Operation under JCS or data logger control automatically regenerates saturated sensors. The option board can control regeneration on a regular basis, every 6, 12 or 24 hours.

The regeneration intervals are set through a combination of switch settings as shown in the following table:

----- SW100----- Switch #1 Switch #2		REGENERATION Interval (Hrs.)
OFF	OFF	OFF
ON	OFF	6
OFF	ON	12
ON	ON	24

Auto-Sample

If a data logger is either not connected or is operating in the manual sampling mode, the following automatic sampling rates may be selected with option board's SW100 dip switch settings:

Dip switch settings			Sampling frequency
3	4	5	
ON	ON	ON	No automatic sampling
OFF	ON	ON	5 minutes
OFF	OFF	ON	15 minutes
OFF	ON	OFF	30 minutes
OFF	OFF	OFF	1 hour

The switches have no effect if a data logger is connected and operating in automatic sampler mode as programmed through the JCS.

4-20 mA Analog Output

The analog output signal at pin 18 of the 25 pin connector can be configured to provide the instrument's native mode 0-2 Volt output or the optional 4-20 mA output by setting the option board jumper (SW101) to the "V" position for voltage, or the "I" position for current. (Pin 23 is the ground pin for the analog output function. Pin 18 is positive with respect to the ground pin).

- The 0-2 Volt output circuit can drive loads of 10 k ohms or higher.
- The 4-20 mA output is a passive transmitter and requires the connected receiver to supply between 10 and 28 volts of excitation potential.

The analog output signal is based on the entire range (0-.999 mg/m³).

Note that neither analog output circuit is floating. The negative terminals of both circuits are connected to the instrument's common ground buss.

SW101 Functions:

V =	0-2V analog output
I =	4-20 ma analog output

Jerome® 431-X instruments shipped after early 1995 are capable of providing 0-2 volts analog output. Instruments shipped before that time can be upgraded by a firmware update and adjustment.

Instruments that are capable of 0-2 volt output can be upgraded to the 4-20 mA output with the addition of an option board upgrade. This must be installed at the factory.

Connection and Setup:

- 0-2 volt devices connect as shown in Figure 1. If the instrument includes an option board, be sure its analog jumper (SW101) is set to the “V” position.

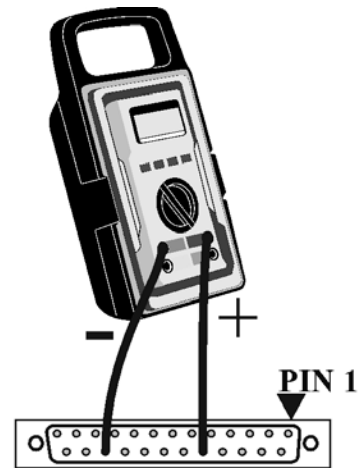

**REAR OF CONNECTOR,
CONNECT PINS 18 AND 23 FOR
0-2 VOLT OUTPUT.
JUMPER ON BOARD IS AT “V”
Figure 1**

- The 4-20 mA active receivers connect as shown in Figure 2. The active receiver contains a voltage source to power the loop current. The receiver must have an isolated input circuit. That is, it must not be connected to ground or to a voltage source referenced to ground. Be sure that jumper SW101 is set to the “I” position before power is applied.

- 431X reading Current
0.000mg/m3 4mA
1.000mg/m3 20mA

- The 431X current formula is:
 $16mA * \text{Display Reading} + 4mA = (\text{Current})$

Example:

A reading of .100mg/m³ would produce an output current of:
 $16mA * 0.1 + 4mA = 5.6mA$

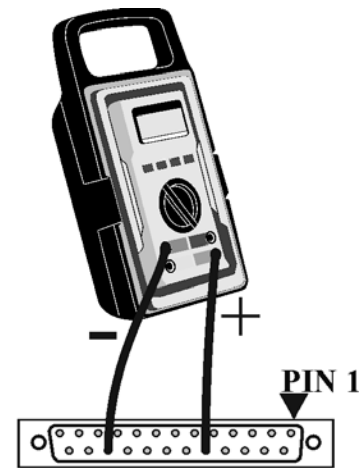

**REAR OF CONNECTOR,
CONNECT PINS 18 AND 23 FOR
4-20 mA OUTPUT.
JUMPER ON BOARD IS AT “I”
Figure 2**

- The 4-20 mA passive receivers do not contain a voltage source to power the loop current. They require the addition of a separate isolated power supply. Typically a supply that delivers 15 to 20 volts DC at 50 mA is sufficient. Wire these as in Figure 3. Note that some 12-volt DC wall transformers (as used on portable equipment) may deliver 15 to 20 volts when they are lightly loaded. The Digi-Key T509-P1P-ND is a commonly available example of a 12 volt 200mA supply that will deliver around 18 volts nominal when loaded below 20 mA.
- Be sure that both the power supply used and the passive receiver are floating (not connected to earth ground). If either is not floating, the circuit will not work and damage may occur.
- Ensure that jumper SW101 is set to the “I” position before power-up.

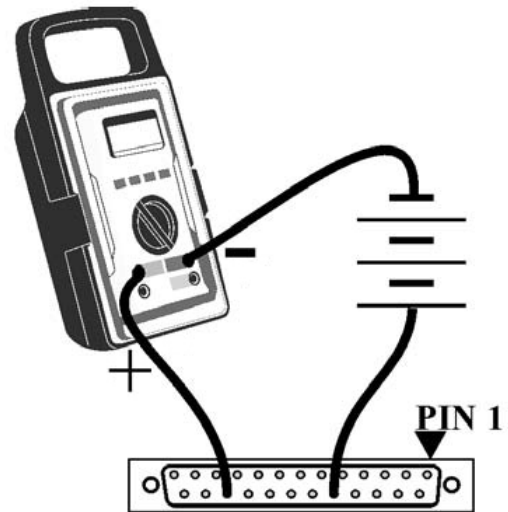

**REAR OF CONNECTOR,
CONNECT PINS 18 AND 23 FOR
4-20 mA OUTPUT.
JUMPER ON BOARD IS AT “I”
Figure 3**

Fresh Air Solenoid

An external three-way solenoid can be used to provide fresh air or conditioned air during sensor regeneration. This may be necessary if the sample stream lacks molecular oxygen. A low current six volt DC solenoid, connected between pins 19 and 11 of the 25 pin rear panel connector, will be energized during the regeneration cycle if the option board SW100 switch 6 is placed in the OFF position.

If needed, the circuit may be built from the following components and configured as shown in the following diagram. It will only function if the option board is installed in the 431-X instrument.

Required Parts:	Suggested Part	Similar AZI P/N
1 solenoid, 6volt 3way	Angar P/N 407569	1300 1004
1/8" to 1/16" tubing adaptor	Any	1300 0025
1/2" clamp, adhesive mount	Any	6000 0013
1/8" tube to instrument adaptor	Any	1400 3010
3" 1/8" tubing	Tygon Formula R3603	2500 3001
A/R 1/16" tubing	Tygon Formula R3603	2500 3002
1 25 pin male DB-25 connector Solder-cup style	AMP 747912-2	None *
1 connector hood	AMP 749626-2	None *

* These are types not stocked by AZI, but should be available overnight from many AMP stocking distributors such as Digi-Key Corporation. There are multiple suitable alternatives such as Radio Shack's 276-1547 and 276-1549.

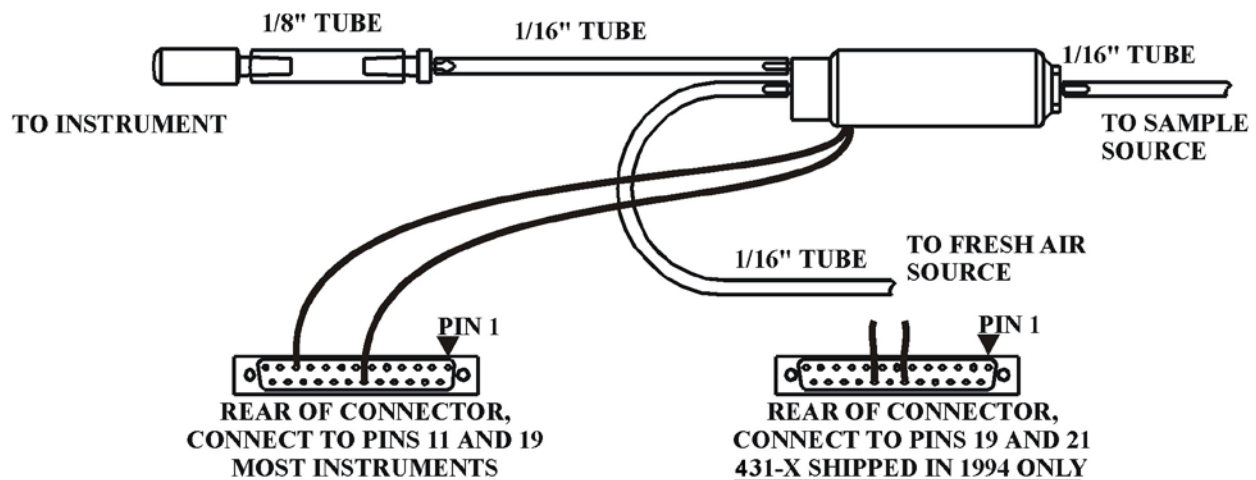

DC Power Operation

Instruments with the 431-X option board modification can be used with any +12 VDC source for continuous operation, if the AZI Power Inverter Kit, P/N Y031 0902 is installed along with the option board. To preserve the life of the DC power source, usually a car or truck battery, the power inverter will switch on automatically to supply the AC necessary for regeneration only. The external switch on the inverter should always be OFF to preserve battery life during normal sampling.

To work with the power inverter kit, place option board SW100 DIP Switch #6 to the ON position.

When the instrument starts a regeneration with option board SW100 DIP Switch #6 ON, the instrument sends a signal to close the relay on the DC Power Adaptor, AZI P/N 1000 0089, mounted between the data logger and the instrument. This switches the power inverter ON using the inverter's internal switch.

NOTE: When this mode is enabled, the instrument does NOT check for 115 VAC for the regeneration. If there is no AC power to the instrument, and a regeneration is initiated, the instrument will flash .H.H.H (rather than .P.P.P), however the sensor will not heat, nor will the sensor be cleaned.

DC Power Adaptor Kit, AZI P/N Y031 0902

- The DC power adaptor kit consists of:
 - DC Power Adaptor, P/N 1000 0089
 - DC Power Inverter, P/N 4000 1021
 - DC Power Cable Assembly, P/N 6000 1093

Installation

- Ensure that the instrument's option board switches are set correctly for the intended operation with the option board's SW100 DIP Switch #6 set to "ON" for DC operation.
- Mount the interface board to the rear of the instrument. Tighten the mounting screws.
- Place or mount the DC/AC power inverter in a secure position near the instrument.
- Connect the cable from the DC/AC power inverter to the matching connector on the interface board. Note that the connectors are keyed to prevent improper connection.
- Plug the instrument's AC power cord into the power inverter and connect it to the instrument.

Ensure that the inverter's power switch is in the "OFF" position. LEAVE the power switch in the "OFF" position at all times. The interface board will activate the inverter when necessary. If the inverter power switch is placed in the "ON" position, it will cause a continuous drain on the external 12-volt power system.

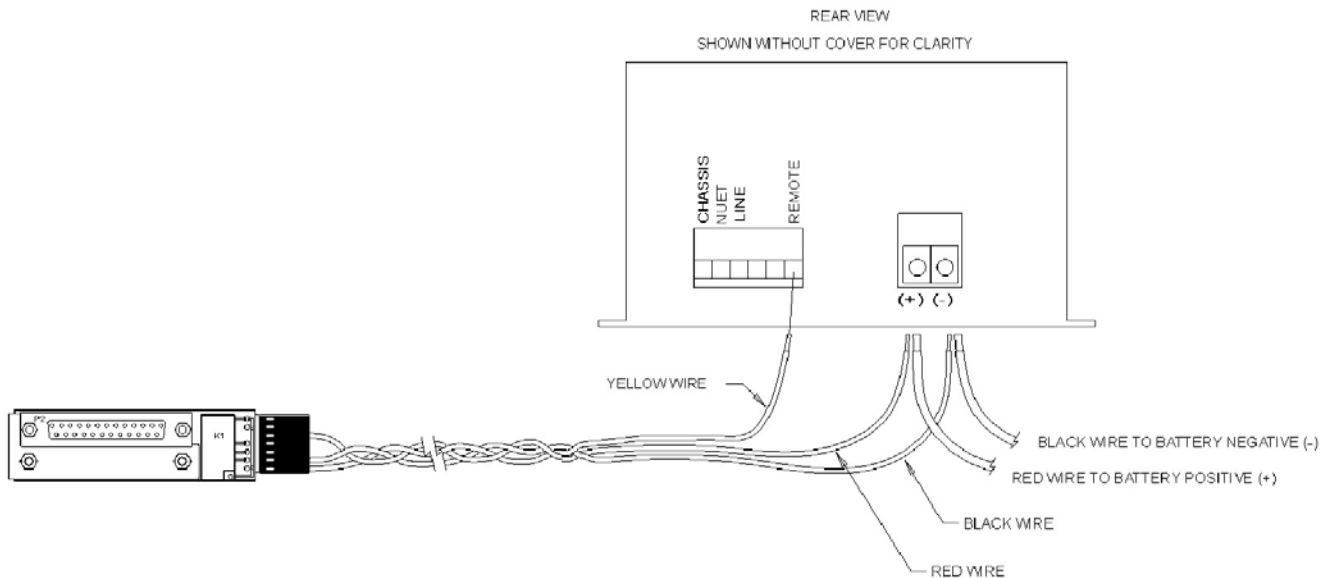

- Remove the screws from the rear cover of the inverter and remove the cover.
- Place the wires from the external DC source (battery) and the wires from the DC power cable through the holes in the end plate.
- Connect cables from the external 12-volt power source and the DC power cable assembly to the appropriate positive (+) and negative (-) terminals on the back of the inverter and tighten the hold down screws.
- Connect the yellow wire from the DC power cable to the "REMOTE" terminal on the power inverter and tighten the hold down screw.
- Reinstall the cover.
- If the external 12volt lines are not powered, power them now. (Connect them to the battery)
- Connect the instrument's AC power cord between the instrument and the front of the power inverter.
- Turn the instrument "ON." (Note, the external 12V supply will also charge the instrument internal battery).
- Press the "REGEN" switch on the instrument. Inverter operation can be verified in either of two ways:
 - Immediately after pressing "REGEN" the inverter will intermittently "sing." This tone slowly becomes nearly continuous and then ends after 64 seconds.
 - If the area is noisy, use a voltmeter or test lamp to verify that approximately 115 volts is present for about 64 seconds, starting when the "REGEN" switch is pressed.
- Allow the instrument to complete its regeneration before turning it off.
- With the instrument turned off, complete the installation (i.e. connect data logger, communications cables, or other devices and ensure that the DIP switches for the instrument and option board are set correctly).

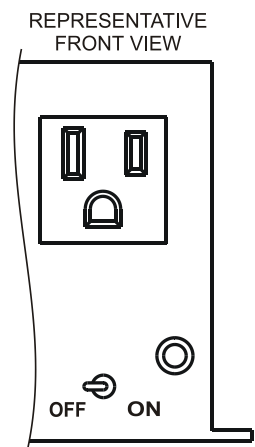

15. WARRANTY

Arizona Instrument LLC (seller) warrants to buyer that Jerome® products delivered pursuant to this agreement shall, at the time of delivery, and for a period of one (1) year. Thereafter (the Internal Battery Pack, where applicable, is warranted for a period of ninety [90] days only), to be free from defects in material or workmanship and shall conform to seller's specifications or such other specifications as seller has agreed to in writing. Seller's obligations with respect to claims under this warranty shall be limited, at seller's option, either to the replacement of defective or non-conforming product or to an appropriate credit for the purchase price thereof subject to the provisions of seller's Warranty Policy as amended from time to time, said Policy being incorporated herein by reference. All defective parts replaced by AZI become the property of AZI.

Returned products under warranty claims will be shipped to seller's plant by buyer at buyer's expense and shall be accompanied by a statement of the reason for the return and an approved Return Material Authorization Number issued by seller. Buyer remains responsible for payment for products not accepted for warranty adjustment, handling costs, and freight costs associated therewith.

Notwithstanding the foregoing, no warranty shall be enforceable in the event that product has been subjected to environmental or stress testing by buyer or any third party without written approval of seller prior to such testing. Further, no warranty shall be enforceable if the alleged defect is found to have occurred because of misuse, neglect, improper installation, repair, alteration, accident, or improper return handling procedure by buyer.

Discontinued product is warranted only for a credit or replacement at seller's option.

THE EXPRESS WARRANTIES GRANTED ABOVE SHALL EXTEND DIRECTLY TO BUYER AND NOT TO BUYER'S CUSTOMERS, AGENTS, OR REPRESENTATIVES AND, EXCEPT FOR WARRANTY OF TITLE, IS IN LIEU OF ALL OTHER WARRANTIES, WHETHER EXPRESSED OR IMPLIED, INCLUDING ANY IMPLIED WARRANTIES OF FITNESS FOR A PARTICULAR PURPOSE AND MERCHANTABILITY, SUCH OTHER WARRANTIES BEING SPECIFICALLY DISCLAIMED BY SELLER. IN NO EVENT SHALL EITHER PARTY'S LIABILITY FOR ANY BREACH OR ALLEGED BREACH OF THIS AGREEMENT EXCEED THE TOTAL EXTENDED PRICE OR PRICES SHOWN ON UNFILLED ORDERS, NOR SHALL EITHER PARTY BE LIABLE FOR ANY SPECIAL, INCIDENTAL OR CONSEQUENTIAL DAMAGES RESULTING FROM BREACH OR ALLEGED BREACH.

Notwithstanding the foregoing, if any product covered by order(s) placed hereunder is designated as "developmental," "prototype" or "experimental," no warranty whatsoever except a warranty of title to component materials, will be applicable thereto and buyer shall indemnify seller for any claims for liability asserted seller in connection therewith.

The foregoing state the entire liability of seller in connection with products supplied hereunder.

TRADEMARK AND COPYRIGHT PROTECTION

Jerome[®], Arizona Instrument[®], AZI[®] and the stylized AZI are all registered trademarks of Arizona Instrument LLC.

Instrument firmware is copyright protected.
All specifications subject to change without notice.

Copyright 1990-2015 Arizona Instrument LLC. All Rights Reserved.

Resisorb[®] is a registered trademark of Avantor Performance Materials.
Tygon[®] is a registered trademark of Norton.

Arizona Instrument LLC
Jerome[®] 431-X Mercury Vapor Analyzer Operation Manual
Part Number 700-0046

If you have any questions regarding the operation of this instrument, please call our toll free number (800) 528-7411. Internationally, call (602) 470-1414 or fax (480) 804-0656.